

NEXT ASSEMBLY
R.T.E. 1414

ISSUE	REVISION RECORD	DATE	APPD.
-------	-----------------	------	-------

H44-9 HOOK (RELEASE-A-MATIC)

DIMENSIONAL DATA
COMMERCIAL TOLERANCE APPLIES

SPECIFICATIONS

MATERIAL:
STEEL

STRENGTH: (TENSION)
SAFE WORKING-18,000 LBS.
PROOF-35,850 LBS.
MINIMUM BREAK-71,700 LBS.
MAXIMUM RELEASE LOAD-10,000 LBS.
LOAD REQ'D FOR RELEASE-25 LBS.

FINISH:
ZINC PLATED

WEIGHT:
5.0 KGS. [11.0 LBS.]

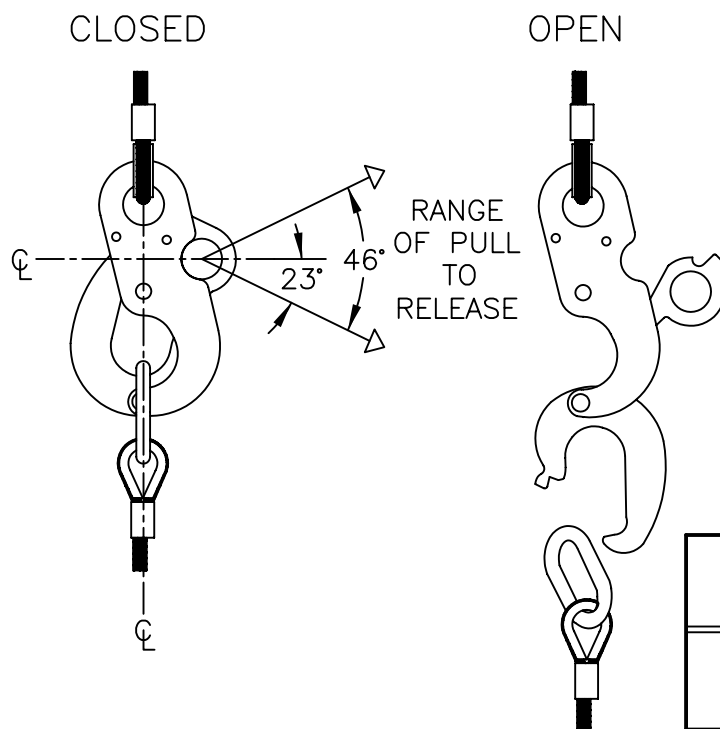
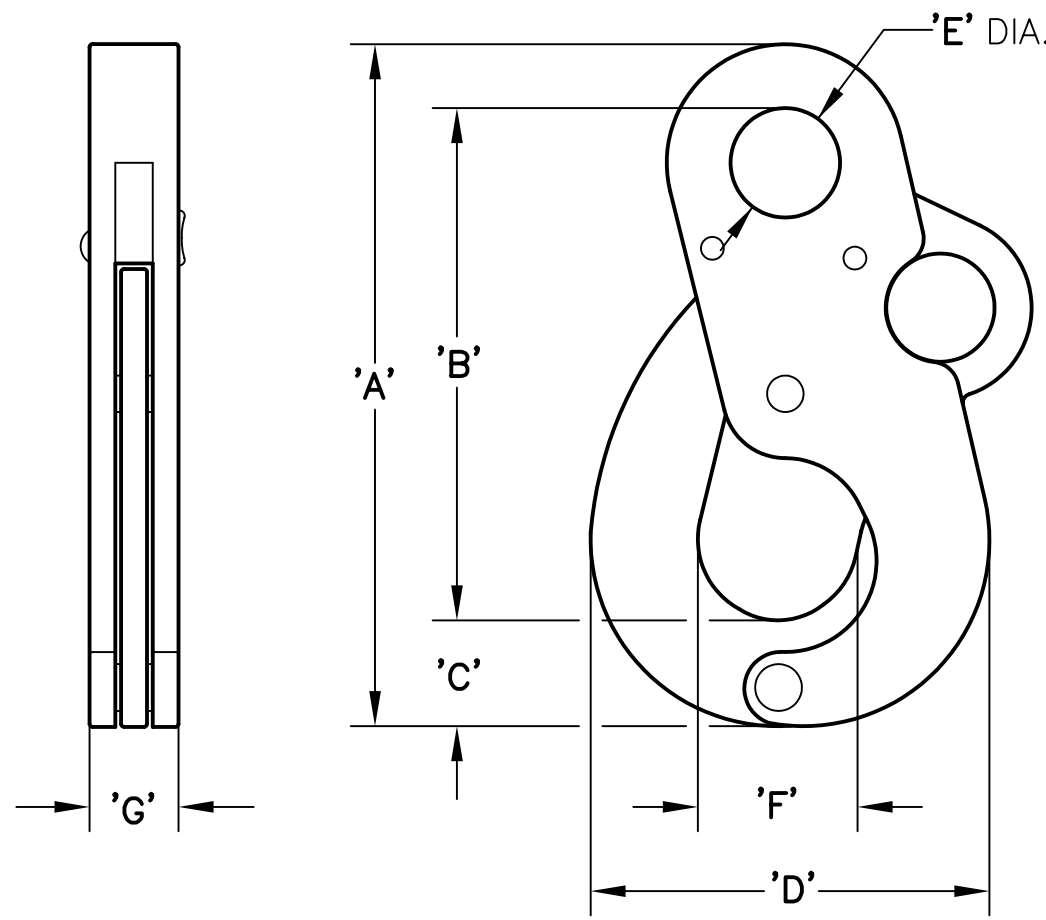
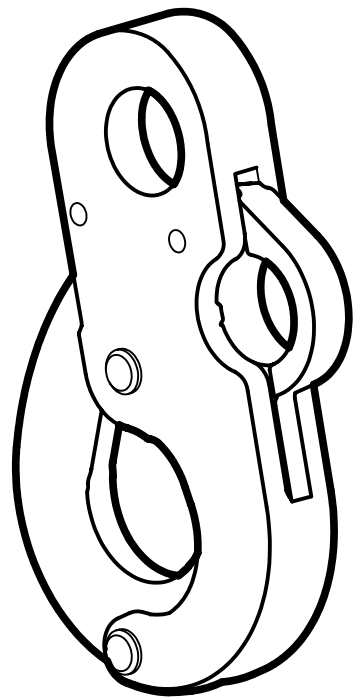

APPLICATION

MODEL NO.	DIM.	'A'	'B'	'C'	'D'	'E'	'F'	'G'
H44-9	MM	241.3	177.8	39.6	143.0	38.1	57.1	49.2
	(INCH)	(9.50)	(7.00)	(1.56)	(5.63)	(1.50)	(2.25)	(1.94)

**H44-9
HOOK
(RELEASE-A-MATIC)**

Peck & Hale PECK & HALE
180 DIVISION AVENUE
W. SAYVILLE, N.Y. 11796 U.S.A.

THIS DRAWING AND ANY PRINT MADE THEREFROM IS THE EXCLUSIVE PROPERTY OF PECK & HALE, IT MUST NOT BE TRACED NOR REPRODUCED IN ANY MANNER NOR SHALL IT BE SUBMITTED TO OUTSIDE PARTIES FOR EXAMINATION WITHOUT OUR WRITTEN CONSENT. IT SHALL BE USED ONLY AS MEANS OF REFERENCE TO WORK DESIGNED OR FURNISHED BY US.

FSCM No: 94658	DRN: S. JEFFREY	SHEET	OF
DATE: 11/15/12	CHK:	4995	DWG. NO.
SCALE: NONE	APPD:		