



Lifting Eye Nut RUD RM

Product information

Octagonal lifting eye approved for lifting. Lifting with an angle of inclination is allowed with reduction of WLL (see diagram at blueprint) but we strongly recommend to use the Rud RM lifting eye only for straight lifting.

Applied harmonized norms: DIN EN ISO 12100: 2011-03

Material: Forged high tensile steel.

Marking: According to standard, CE-marked

Temperature range: -40° up to 200°C (no reduction of WLL)

Standard: EN 1677-1

Warning: RUD RM eye nuts are only to be used with bolts or threaded studs with a min. quality class 8.8 and who are 100 % crack detected. Non certified bolts or threaded studs are not allowed.

Safety factor: 4:1

Grade: 8

Part Code	WLL ton	Thread mm	WLL 90° ton	A mm	B mm	C mm	D mm	E mm	T mm	Weight kg	Delivery time
421100040230	0.4	M6	0.1	12	11	10	25	25	34	0.1	17
421100080230	0.8	M8	0.2	12	11	10	25	25	34	0.1	17
421100100230	1	M10	0.25	12	11	10	25	25	34	0.1	17
421100160230	1.6	M12	0.4	14	13	12	30	30	41	0.2	17
421100200230	3	M14	0.75	16	15	14	35	35	48	0.3	17
421100320230	3.2	M16	0.8	16	15	14	35	35	48	0.3	17
421100480230	4.8	M18	1.2	18	17	16	40	40	55	0.4	17
421100600235	6	M20	1.5	18	17	16	40	40	55	0.35	17
421100800235	8	M24	2	22	21	20	50	50	70	0.6	17
421101200230	12	M30	3	28	26	24	60	60	85	1.3	17
421101600230	16	M36	4	40	43	38	90	100	130	5.65	17
421102400230	24	M42	6	40	43	38	90	100	130	5.4	17
421103200230	32	M48	8	40	43	38	90	100	130	5.3	17

Blueprint

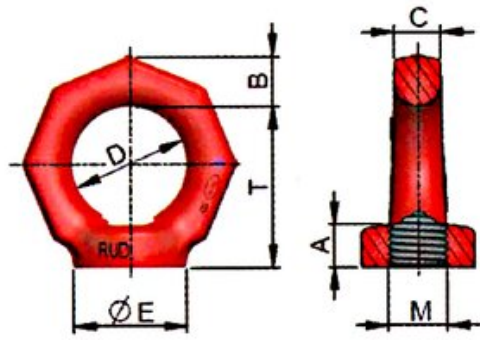

Lifting Method			
Angle of inclination β	0°	90°	0°
WLL Factor	1	0.25	2
For these lifting methods we recommend lifting points which can be adjusted to the direction of pull!			